

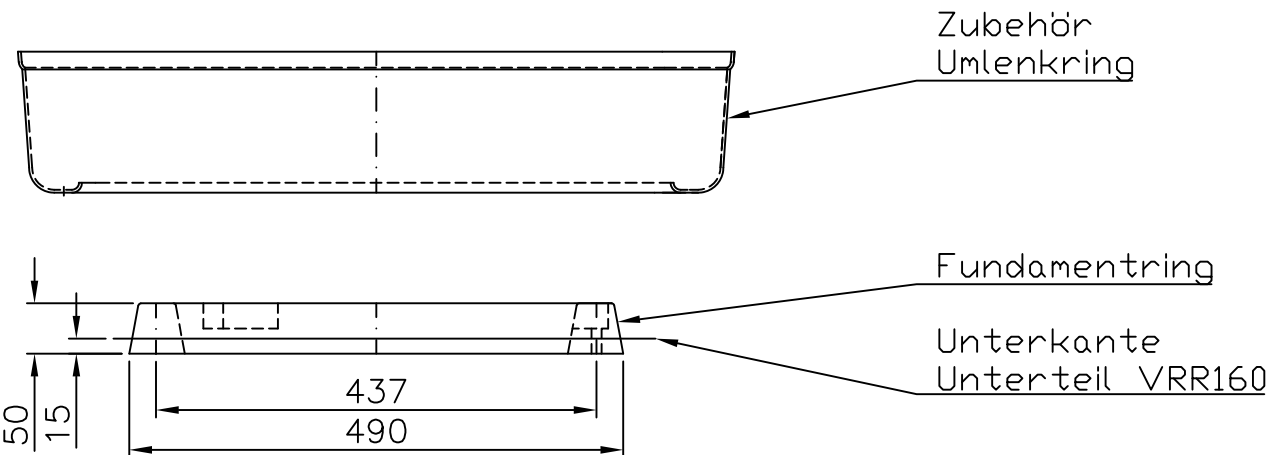

ohne Umlenkring

mit Umlenkring

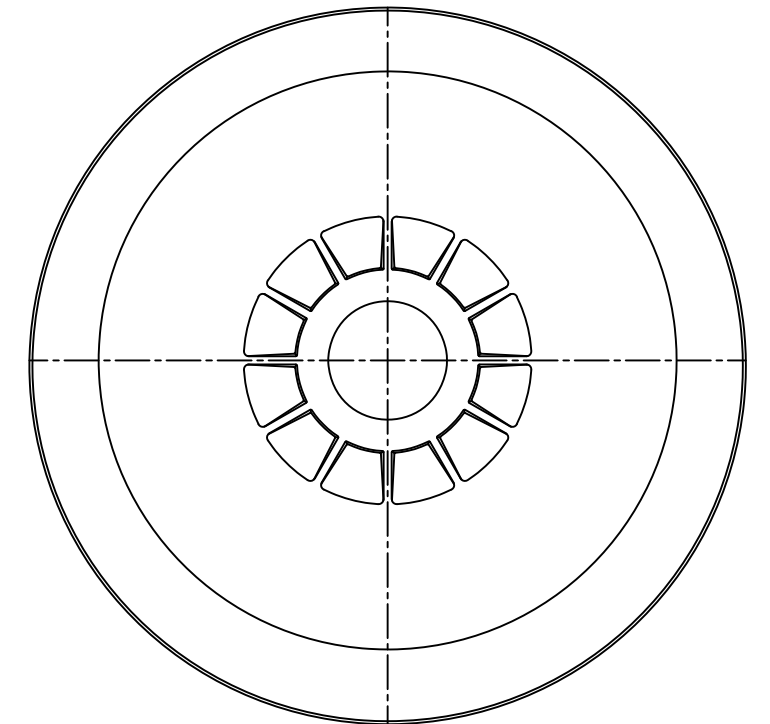
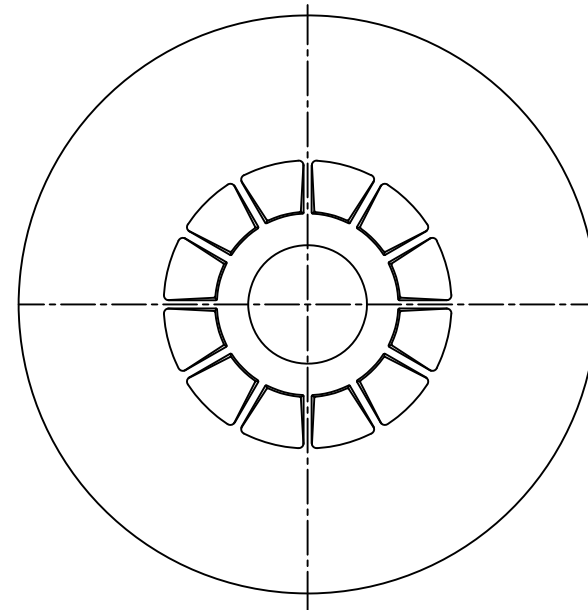
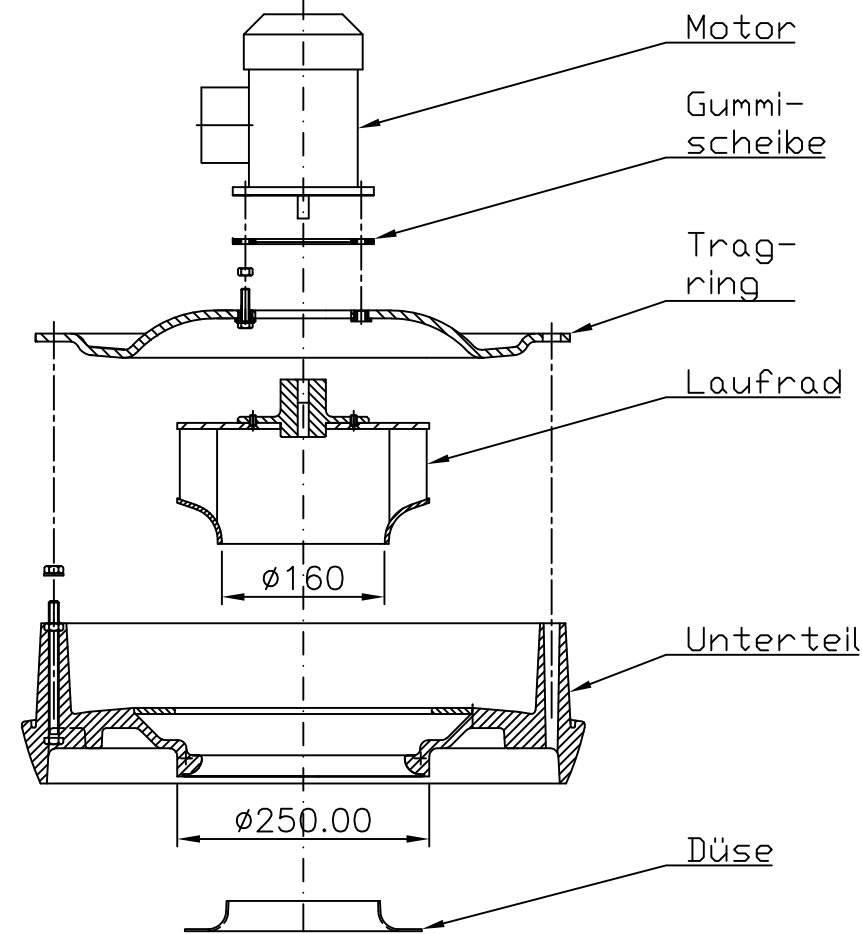
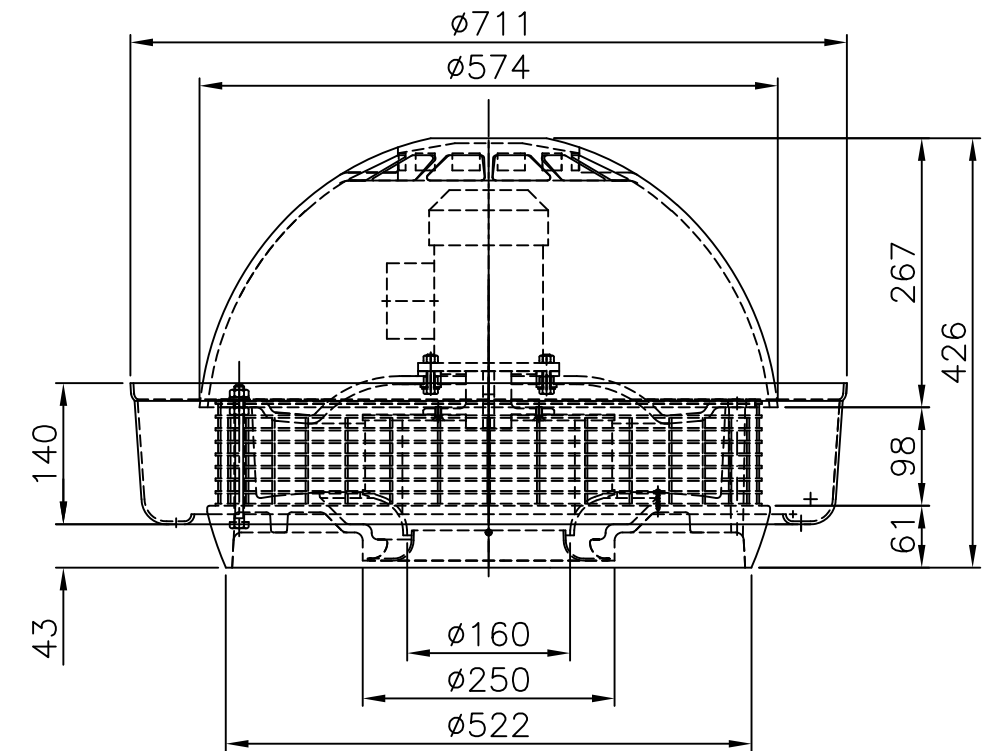
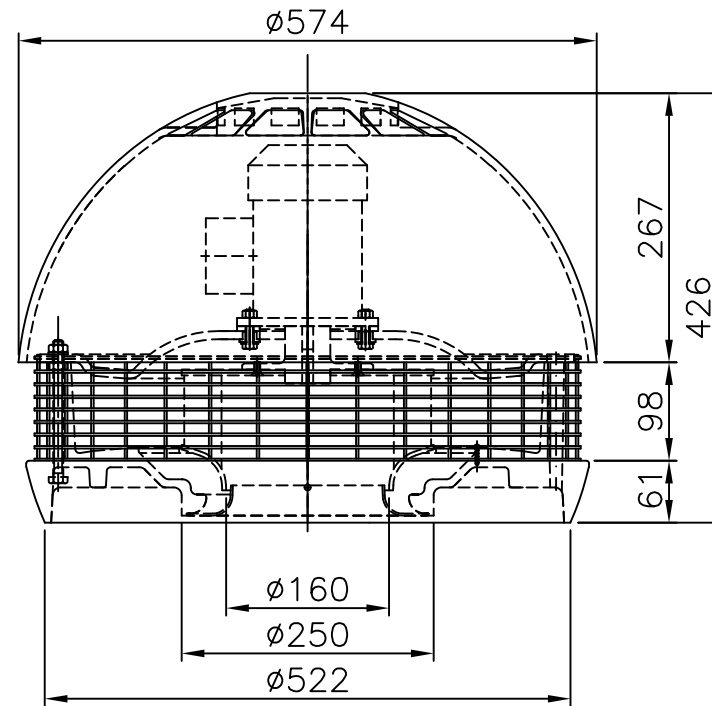
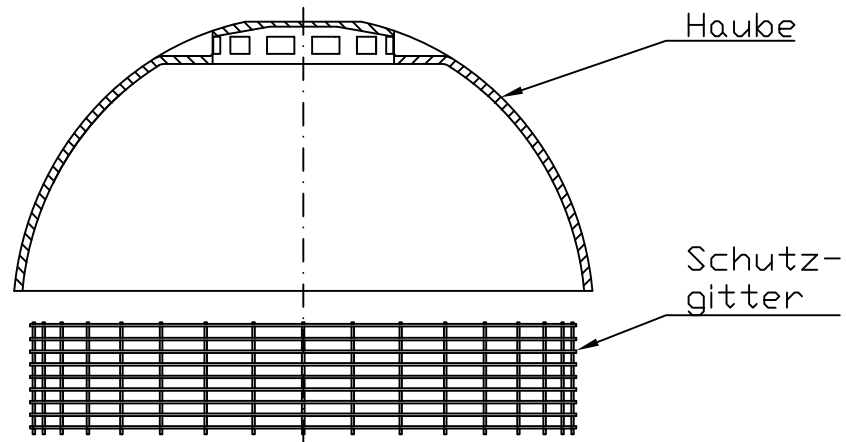

				Halbzeug/Werkstoff	zul. Abw. f. Maße ohne Toleranzang.	
				PPs	grob nach DIN 7168	
				Benennung	Maßstab 1:7.5	
				VRR160/701W	Bl.-Anz. Bl.-Nr. 1 1	
				ÄZ	Masse	
				2015	-	
				Datum		
				29.09.		
				Name		
				Rißler		
				Zeichn.-Nr.		
				VRR160/701W		
				H\ZEICHNMB\VRR\VRR160.dwg		
				Ers. für	Ers. durch	
				-	-	
				 GmbH Lufttechnik Dresden Großenhainer Str. 137 - 01129 Dresden		